

100 TONNE ALL TERRAIN CRANE (GROVE GMK 4100-L)

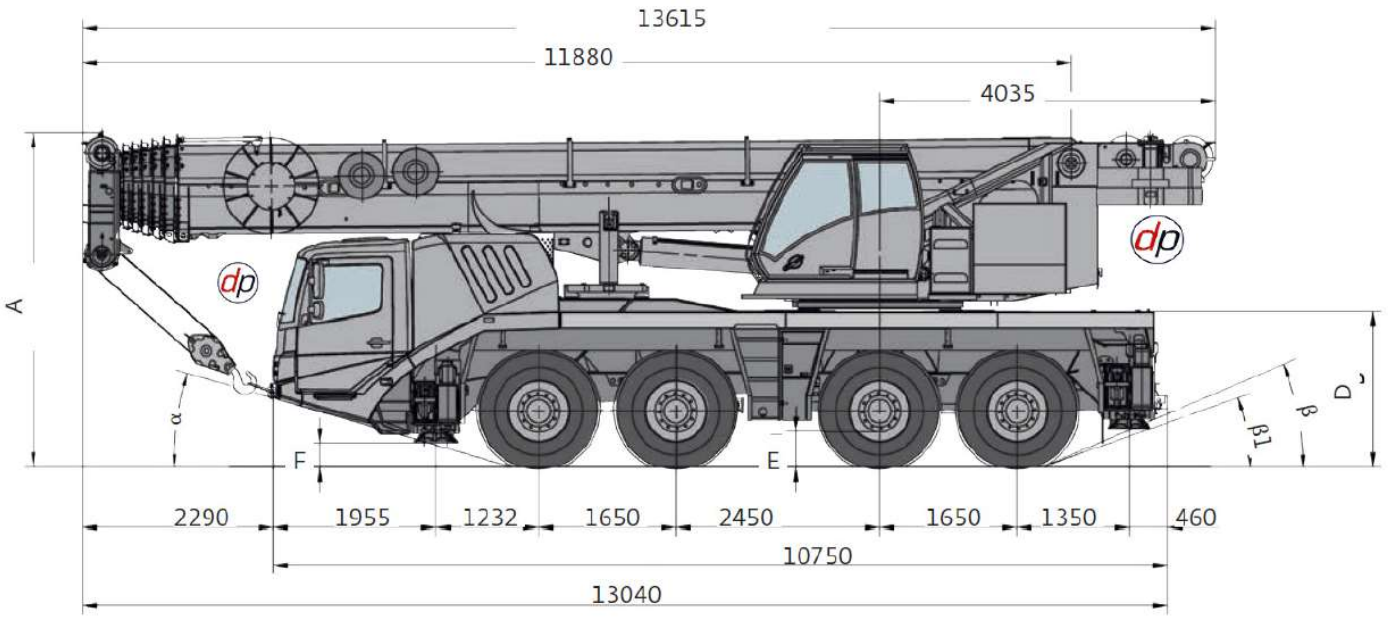

* Lowered

	A	A 130 mm*	B	C	D	E	F	α	β	β1
14.00 R25	3940	3810	2750	2320	1750	435	262	14	21	17
16.00 R25	3990	3860	2750	2280	1863	485	292	16	23	19
20.5 R25	3990	3860	2880	2320	1863	485	292	16	23	19

GROVE
GMK4100-L

NEED ADVICE?
 We have experienced staff who can help you. We can visit your site to discuss your needs.
+44 (0) 1902 405553

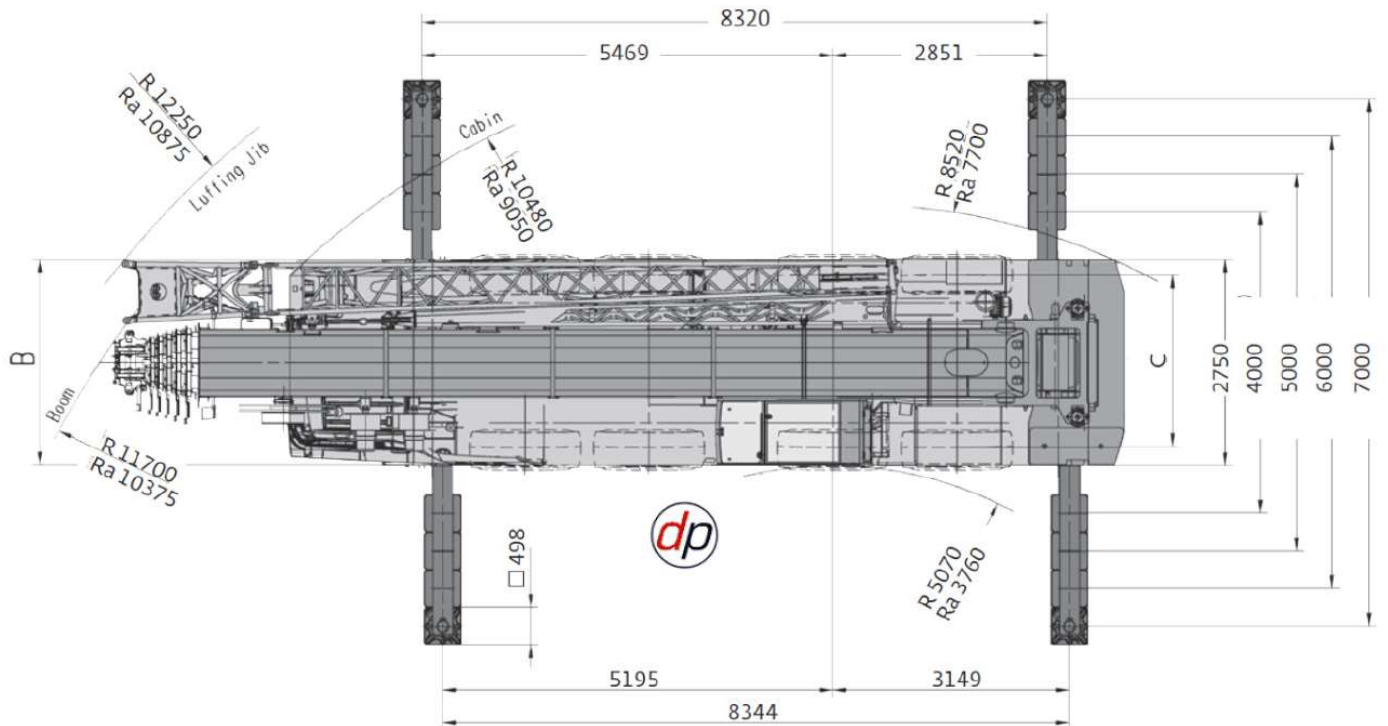

100 TONNE ALL TERRAIN CRANE (GROVE GMK 4100-L)



BALLAST AS CARRIED FOR UK ROAD TRAVEL.



EN 13000

m	11,65	15,90	20,11	24,26	28,25	32,11	35,83	40,08	44,29	48,43	52,43	56,28	60,00	m
3,0	69,5	63,5	59,0	56,0	-	-	-	-	-	-	-	-	-	3,0
4,0	58,0	56,0	52,5	49,5	47,0	-	-	-	-	-	-	-	-	4,0
5,0	49,5	49,5	47,0	44,5	41,5	37,5	30,0	-	-	-	-	-	-	5,0
6,0	43,0	43,5	41,5	40,5	38,0	36,5	30,0	23,0	-	-	-	-	-	6,0
7,0	38,0	38,5	37,5	36,5	35,0	33,5	30,0	23,0	18,0	-	-	-	-	7,0
8,0	34,0	34,5	34,0	33,0	32,0	31,0	29,5	23,0	18,0	14,3	-	-	-	8,0
9,0	30,0	31,0	31,0	30,0	29,5	28,0	27,5	22,5	18,0	14,3	11,6	-	-	9,0
10,0	-	27,5	28,0	26,5	26,0	24,5	24,0	21,5	18,0	14,3	11,6	9,5	-	10,0
11,0	-	23,5	23,5	23,0	23,0	22,5	21,5	20,0	17,7	14,3	11,6	9,5	8,0	11,0
12,0	-	20,5	20,5	21,0	20,5	20,5	19,1	17,9	17,0	14,3	11,6	9,5	8,0	12,0
13,0	-	17,9	18,5	18,6	18,3	18,5	17,2	16,0	15,4	14,2	11,6	9,5	8,0	13,0
14,0	-	-	16,4	16,4	16,5	16,7	15,5	14,6	13,9	13,6	11,6	9,5	8,0	14,0
15,0	-	-	14,6	14,7	15,3	15,0	14,1	14,0	12,6	12,3	11,5	9,5	8,0	15,0
16,0	-	-	13,1	13,4	13,8	13,5	12,8	13,1	11,4	11,2	11,1	9,5	8,0	16,0
18,0	-	-	-	11,5	11,4	11,1	11,3	11,1	9,5	9,4	9,3	9,5	8,0	18,0
20,0	-	-	-	9,6	9,5	9,5	9,7	9,2	8,0	8,3	8,1	8,2	8,0	20,0
22,0	-	-	-	-	8,1	8,6	8,3	7,7	7,2	7,7	7,5	7,6	7,0	22,0
24,0	-	-	-	-	7,3	7,4	7,1	6,6	6,6	7,0	6,9	6,6	6,0	24,0
26,0	-	-	-	-	-	6,4	6,1	5,6	6,0	6,0	6,0	5,7	5,2	26,0
28,0	-	-	-	-	-	5,6	5,3	4,8	5,3	5,2	5,3	5,0	4,5	28,0
30,0	-	-	-	-	-	-	4,6	4,5	4,9	4,8	4,6	4,3	3,8	30,0
32,0	-	-	-	-	-	-	4,0	4,2	4,3	4,2	4,0	3,7	3,3	32,0
34,0	-	-	-	-	-	-	-	3,9	3,7	3,7	3,4	3,1	2,8	34,0
36,0	-	-	-	-	-	-	-	2,5	3,4	3,2	2,9	2,7	2,3	36,0
38,0	-	-	-	-	-	-	-	-	3,0	2,8	2,5	2,3	1,9	38,0
40,0	-	-	-	-	-	-	-	-	2,6	2,4	2,2	1,9	1,5	40,0
42,0	-	-	-	-	-	-	-	-	-	2,1	1,8	1,6	1,2	42,0
44,0	-	-	-	-	-	-	-	-	-	1,8	1,5	1,2	-	44,0
46,0	-	-	-	-	-	-	-	-	-	-	1,3	0,9	-	46,0
48,0	-	-	-	-	-	-	-	-	-	-	1,0	-	-	48,0

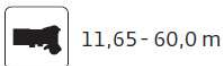

REQUIRES EXTRA BALLAST DELIVERY BY TRANSPORT.



EN 13000

m	11,65°	11,65	15,90	20,11	24,26	28,25	32,11	35,83	40,08	44,29	48,43	52,43	56,28	60,00	m
2,5	100,0	-	-	-	-	-	-	-	-	-	-	-	-	-	2,5
3,0	69,0	69,5	63,5	59,0	56,0	-	-	-	-	-	-	-	-	-	3,0
4,0	59,0	58,5	56,0	52,5	49,5	47,0	-	-	-	-	-	-	-	-	4,0
5,0	52,0	50,0	49,5	47,0	44,5	41,5	37,5	30,0	-	-	-	-	-	-	5,0
6,0	46,0	43,5	44,0	41,5	40,5	38,0	36,5	30,0	23,0	-	-	-	-	-	6,0
7,0	41,0	38,0	38,5	37,5	36,5	35,0	33,5	30,0	23,0	18,0	-	-	-	-	7,0
8,0	36,0	34,0	34,5	34,0	33,0	32,0	31,0	29,5	23,0	18,0	14,3	-	-	-	8,0
9,0	30,0	30,0	31,0	31,0	30,0	29,5	28,5	28,0	22,5	18,0	14,3	11,6	-	-	9,0
10,0	-	-	28,0	28,5	27,5	27,5	26,0	26,0	21,5	18,0	14,3	11,6	9,5	-	10,0
11,0	-	-	25,5	25,5	25,5	25,5	24,0	24,0	20,5	17,7	14,3	11,6	9,5	8,0	11,0
12,0	-	-	22,5	23,0	22,5	23,0	21,5	21,5	19,1	17,0	14,3	11,6	9,5	8,0	12,0
13,0	-	-	19,7	20,0	19,8	20,5	19,7	19,3	17,9	16,2	14,2	11,6	9,5	8,0	13,0
14,0	-	-	-	17,7	18,3	18,1	18,6	17,5	16,4	15,3	14,0	11,6	9,5	8,0	14,0
15,0	-	-	-	16,4	16,5	16,2	16,8	15,9	14,9	14,4	13,3	11,5	9,5	8,0	15,0
16,0	-	-	-	14,8	14,8	14,8	15,2	14,6	13,6	13,1	12,6	11,3	9,5	8,0	16,0
18,0	-	-	-	-	12,2	12,8	12,5	12,0	12,4	11,0	10,8	10,6	9,5	8,0	18,0
20,0	-	-	-	-	10,8	10,8	10,5	10,4	10,5	9,3	9,2	9,2	9,0	8,0	20,0
22,0	-	-	-	-	-	9,2	8,9	9,4	8,9	7,9	7,8	7,9	8,0	7,7	22,0
24,0	-	-	-	-	-	8,0	8,2	8,1	7,6	6,6	7,1	6,9	7,1	7,1	24,0
26,0	-	-	-	-	-	-	7,4	7,0	6,5	6,0	6,6	6,3	6,4	6,2	26,0
28,0	-	-	-	-	-	-	6,5	6,1	5,6	5,3	6,0	5,6	5,7	5,4	28,0
30,0	-	-	-	-	-	-	-	5,4	4,9	5,0	5,3	5,2	5,1	4,7	30,0
32,0	-	-	-	-	-	-	-	4,7	4,2	4,6	4,6	4,6	4,4	4,1	32,0
34,0	-	-	-	-	-	-	-	-	3,9	4,4	4,1	4,1	3,9	3,5	34,0
36,0	-	-	-	-	-	-	-	-	3,2	4,0	3,8	3,6	3,4	3,0	36,0
38,0	-	-	-	-	-	-	-	-	-	3,5	3,4	3,2	2,9	2,6	38,0
40,0	-	-	-	-	-	-	-	-	-	3,1	3,0	2,8	2,5	2,2	40,0
42,0	-	-	-	-	-	-	-	-	-	-	2,7	2,4	2,2	1,8	42,0
44,0	-	-	-	-	-	-	-	-	-	-	2,4	2,1	1,8	1,5	44,0
46,0	-	-	-	-	-	-	-	-	-	-	-	1,8	1,5	1,2	46,0
48,0	-	-	-	-	-	-	-	-	-	-	-	1,6	1,3	0,9	48,0
50,0	-	-	-	-	-	-	-	-	-	-	-	-	1,0	-	50,0

* 0° over rear, nach hinten, en arrière, por la parte trasera, sul posteriore, Над задней частью